

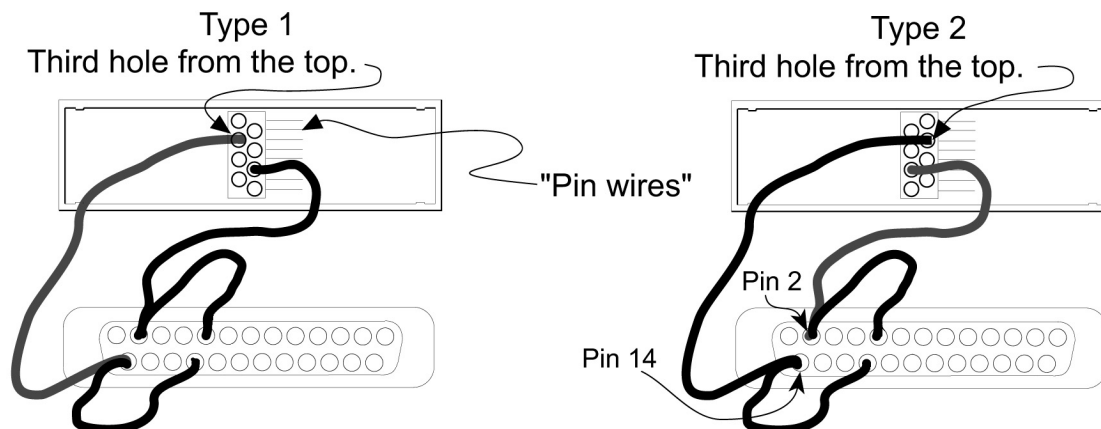

RS485-DB25 Modular Jack Adapter

Assembly notes: Acroprint orders the adaptors which have six wires already connected to the Modular Jack (RJ-11 type). We have seen 2 different types of these, as explained below.



- A. Orient the adaptor so that it matches the illustration above - looking down into the back of the shell, with the "pin wires" extending to the right.
- B. Notice that both Type 1 and Type 2 are really wired the same. Connections are made on only two places on the RJ-11 side. Cut off any connection wires which are not used - close to where they extend from the small connector block. Save these extra wires for making the jumper.
- C. Make the jumper by stripping one end of an extra wire approximately 1/8", then solder to the back part of the pin of the wire to be jumpered. Be careful not to get solder into the barrel of the pin to be inserted into the DB-25 holes.
- D. Plug the connector wires into the DB-25 holes as shown.
- E. Assemble and test using fixture 90-0122-000.

25-0121-0000 Converter Assembly

(Includes Converter, Adapter and Reversed Modular Cable)